

Serial number:



II 2 G, D  
BVS .. ATEX

**Operating Manual**  
**Small-parts Conveyor Drive**  
Special version for areas with potentially explosive atmospheres

**Series eKF... (EEx) (explosion protected version)**

---

## Intended Use

AViTEQ small-parts conveyor drives in special version for areas with potentially explosive atmospheres with the authorisation:



BVS .. ATEX ...  
II 2 G EEx e IIB T4  
II 2 D IP65 T 115°C

are designed and intended as units of the unit group II, category 2 and 3 according to EN 50014 for removing, transporting, conveying, measuring out, and distributing small-grained bulk materials and small parts in areas with the risk of explosion by a gas-, a vapour-, a mist- or a dust-air-mixture.

Operation is only allowed with the associated AViTEQ-controller, which must be installed outside the area with potentially explosive atmosphere. The controller must correspond to the defaults of the associated ATEX-type examination certification. For each small-parts conveyor drive a separate varistor protection unit and a certified (ATEX) motor-protective circuit breaker must be installed.

When completing the small-parts conveyor drive with a working unit (trough, tube or rail) it is to be made certain that no ignition sources result from colliding components. The small-parts conveyor unit (unit of small-parts conveyor drive and working unit) must be able to oscillate freely, without effecting neighbouring components.

## For your safety

You will find three different types of symbols in this operating manual which are intended to point out important information:



**DANGER!**

*The danger warning describes procedures or conditions which could lead to dangerous and even life-threatening consequences for the person installing or using the equipment.*



**ATTENTION!**

*You will find this information with procedures in which a danger of damage to equipment exists. This damage could also result in injury to personnel (e.g., from a fire!).*



**NOTE!**

*Notes provide information regarding individual tasks. Notes explain circumstances, clarify terminology or provide tips for simplifying processes or procedures.*

Even though the AViTEQ small-parts conveyor drives were developed with all safety measures for your protection, handling errors may occur. In the interest of your safety and that of your colleagues, observe the following information:



**DANGER!**

*The small-parts conveyor drives in special version for areas with potentially explosive atmospheres are normally delivered without a connection cable and without a cable gland. Select, depending upon your case of application, a connection cable with a suitable cable cross section, permissible in accordance with the standards. The temperature of the connection cable must not exceed a value of +70°C with gas (zone 1 and 2) or dust (zone 21 and 22) at the cable gland and a value of +80°C inside the terminal box at the terminals. Select a connection cable, that is suitable for a maximum temperature of +80°C and ask us in the case of doubt.*

*Only use cable glands with a metric thread, that are permitted for the use in areas with potentially explosive atmospheres for your particular case. The degree of protection of the cable gland must be at least IP65. Further the cable gland must possess a strain relief.*

*Normally the size of the thread for the cable gland is M16x1,5. As special version also the thread size M20x1,5 is possible. Subsequent changing of the thread size or using extensions, reductions and/or intermediate connecting pieces is **not** allowed and results in the invalidity of the type examination certification (BVS.. ATEX...)!*

***Never** open the cover of the terminal box, as long as voltage is present at the terminals inside the terminal box, because this can be an ignition sources and as a result lead to an ignition of a potentially explosive atmosphere consisting of a gas-, a vapour-, a mist- or a dust-air-mixture.*



When the unit is connected to the mains, a lethal voltage is present inside the controller and the terminal box of the small-parts conveyor drive. Touching electrically live components can be lethal! Before switching on mains power, ensure that no live parts can be touched and the cover of the terminal box is closed!



Inadequate installation may cause the conveyor device to fall down possibly causing injuries or lead to an ignition spark. Ensure that the rubber feet on the lower part are bolted on tight and take appropriate steps to ensure that the conveyor device cannot fall down!



Small-parts conveyor drives in special version for areas with potentially explosive atmospheres must only be operated with the appropriate AViTEQ-controller that is certificated for this case. The controller itself **must not** be installed in areas with potentially explosive atmospheres, and, according to the type examination certification (BVS.. ATEX...), has to be completed with a motor-protective circuit breaker with a ATEX-Certification and a varistor protection unit for every small-parts conveyor drive. In the case of neglect AViTEQ is not liable for the consequences!

**In particular it is prohibited to operate the small-parts conveyor drive with a frequency converter.**

Small-parts conveyor drives in normal version without an ATEX-type examination certification **must not** be operated in areas with potentially explosive atmospheres consisting of a gas-, a vapour-, a mist- or a dust-air-mixture.



Parts that collide with other parts can lead to ignition sources. Before first commissioning, make sure that the working unit can oscillate without colliding with other parts and that all screws are tightend correctly.

The magnet system is coated with a special dark impact-protection lacquer, that anticipates the formation of ignition sparks. However, a so-called collision mode is **not** permitted! In the case of visible damage of the impact-protection lacquer in the area of the electromagnet, the small-parts conveyor drive in special version for areas with potentially explosive atmospheres is not allowed to be operated and has to be sent to AViTEQ for being repaired!



**ATTENTION!**

**Every small-parts conveyor drive must be operated with a separate motor-protective circuit breaker! It is not allowed to add up the currents of several small-parts conveyor drives and then operate them with a common motor-protective circuit breaker!**

*In particular observe the following data on the type label:  $I_A/I_N$  – ratio between the pull-in current  $I_A$  and the rated current (nominal current)  $I_N$  and the time  $t_E$  – time period in which the coil of the electromagnet, as a result of the pull-in current, warms up from the end-temperature during rating mode with an ambient temperature of  $+40^\circ\text{C}$  to the limit temperature.*

---



**ATTENTION!**

*It is totally prohibited that the current consumption of the small-parts conveyor drive exceeds the value of the nominal current specified on the type label, because this leads to temperatures that exceed the respective temperature class. In this case the associated type examination certification (BVS.. ATEX..) becomes invalid and further this may lead to the destruction of the small-parts conveyor drive.*

---



**ATTENTION!**

*Unsuitable controllers, operation without controller or operation with the incorrect mains voltage/frequency could result in damage to the small-parts conveyor drive and are not allowed. Ensure that the connected loads are correct and compare them with the device type labels! Further observe the information in the associated type examination certification (BVS .. ATEX ...).*

*The motor-protective circuit breaker has to be set to the value of the rated current (nominal current) of the small-parts conveyor drive, as it is shown on the the type label of the small-parts conveyor drive! Check this prior to first commissioning and correct, if necessary, the setting, if it isn't correct.*

---



**ATTENTION!**

*Changes of the air gap, the spring rate, the tightening torque of the spring mounting screws, installation without rubber feet and deviations from the intended working weight (see type label) are not allowed and results in the invalidity of the type examination certification (BVS.. ATEX...), because this may lead to excessive heating of the drive, to short circuits between electromagnet windings, and eventually to the destruction of the drive.*

---



**ATTENTION!**

*In the case of applications in the food industry a special lacquering is required that is permitted for the food industry. Please observe this to avoid health risks of others.*

---



**ATTENTION!**

*For making the working unit (trough, tube or rail) all materials are allowed **except** aluminium alloys with a magnesium part by weight greater than 6% and plastic with a surface resistivity greater than  $10^9$  Ohm.*

---



**NOTE!**

*This operating manual refers only to the small-parts conveyor drives of the type: eKF 1-... (EEx); eKF 6-... (EEx) and eKF 12-... (EEx) in accordance with the type examination certification (BVS .. ATEX ...). For small-parts conveyor drives in standard design there is a separate operating manual.*



**NOTE!**

*It is absolutely forbidden to carry out maintenance work. The small-parts conveyor drives in special version for areas with potentially explosive atmospheres are only allowed to be maintained and repaired by AViTEQ Vibrationstechnik GmbH.*

*In the case of non-observance the associated type examination certification (BVS .. ATEX ...) expires. AViTEQ Vibrationstechnik GmbH is not liable for damage to property or person in the case of neglect!*

*The only work, that is allowed, is the electrical connection with opening the cover of the terminal box and the mounting of the working unit.*



**NOTE!**

*For anticipating the formation of ignition sparks by collision of parts of the magnetic system the armature is coated with a special dark impact-protection lacquer. Further the electromagnet is coated with a conductible lacquer. In the case of visible damage of the impact-protection lacquer or the conductible lacquer in the area of the electromagnet, the small-parts conveyor drive in special version for areas with potentially explosive atmospheres is not allowed to be operated and has to be sent to AViTEQ for being repaired!*



**NOTE!**

*Small-parts conveyor drives in special version for areas with potentially explosive atmospheres are, according to the associated type examination certification (BVS .. ATEX ...), designed and permitted for areas with potentially explosive atmospheres consisting of a gas-, a vapour-, a mist- or a dust-air-mixture. A so-called „hybrid operation“, an operation with coexisting potentially explosive atmospheres consisting of a gas-, a vapour-, a mist- and a dust-air-mixture is **not** allowed.*



**NOTE!**

*AViTEQ Vibrationstechnik GmbH possess a certificated quality system for manufacturing small-parts conveyor drives for areas with potentially explosive atmospheres that complies with the requirements of the directive 94/9/EG, Appendix IV. The respective number of the certificate is: DMT 03 ATEX ZQS/E183.*



**NOTE!**

*Depending on the construction of the working unit and the acoustic properties of the material transported, the sound pressure level of the operational small-parts conveyor unit may exceed 70 dB(A). It is the operator's responsibility to ensure adherence to the sound pressure level permitted by means of suitable noise protection measures!*



**NOTE!**

*The item „nominal current“, that is used in this manual corresponds with the rated current and the limit current, as defined in the national standard VDE 0580.*

© 2004 AViTEQ Vibrationstechnik GmbH

## **COPYRIGHT**

The AViTEQ small-parts conveyor drives and this operating manual are protected by copyright. Any reengineering of the units will result in criminal prosecution. All rights of this operating manual are reserved, including reproduction via photo mechanical, print, data or any other possible medium, as well as in translation.

Reproduction of this operating manual, complete or in part, requires the written consent of AViTEQ Vibrationstechnik GmbH.

VIBTRONIC is a registered and protected trademark of AViTEQ Vibrationstechnik GmbH.

This operating manual supports the intended use and appropriate deployment of AViTEQ small-parts conveyor drives. For this purpose, the operating manual describes details that are significant for the product's operation. In particular, the operating manual provides no claim or guarantee of characteristics in the sense specified by §§ 434, 634 BGB (German civil code) or for the success of specific applications.

AViTEQ Vibrationstechnik GmbH is liable for textual errors in the operating manual only where intent and gross negligence are demonstrated. In such cases, liability is limited to the effects the textual errors have on the product specified in the contract and other associated products produced by AViTEQ Vibrationstechnik GmbH as well as required products produced by AViTEQ Vibrationstechnik GmbH which are used in technical combination. This aforementioned liability is limited to cases in which the value or functionality of the agreed upon characteristic of the product specified in the contract is vitiated or considerably diminished. This does not apply if liability for loss of life or limb or loss of health is mandatory.

The textual errors, the damages as well as the justification and resulting causality underlying the liability claim are to be proven by the purchaser. In particular, AViTEQ Vibrationstechnik GmbH is not liable for damages or consequential damages resulting from the incorrect use of the operating manual. This does not apply to faulty content of the operating manual. This does not apply if liability for loss of life or limb or loss of health is mandatory. We are always grateful for suggestions and criticism!

Unless otherwise stated, the relevant state of engineering is that at the time of the combined delivery of the product and the operating manual from AViTEQ Vibrationstechnik GmbH. The product is subject to technical changes without prior notice. Previous operating manuals no longer apply.

The *General Conditions of Delivery Domestic and Abroad* of AViTEQ Vibrationstechnik GmbH apply in their current version.

Do you have questions? Or problems with installation and commissioning?  
Give us a call! We'll be glad to help you!

AViTEQ Vibrationstechnik GmbH  
Im Gotthelf 16  
D-65795 Hattersheim-Eddersheim  
Germany

Telephone +49 (0) 6145 / 503 - 0  
Fax +49 (0) 6145 / 503 - 200  
Telefax Service-Hotline +49 (0) 6145 / 503 - 112  
E-Mail [service@aviteq.de](mailto:service@aviteq.de)

Hattersheim-Eddersheim, 28<sup>th</sup> of October 2004

---

# CONTENTS

<b>1</b>	<b>We are Partners</b>	<b>9</b>
1.1	About this operating manual .....	9
1.2	Product liability and warranty .....	10
1.3	Operative range .....	12
1.4	Installation and operating personnel .....	13
1.5	Safety precautions and responsibilities of the operator .....	13
1.6	EC-Directives .....	14
<b>2</b>	<b>Transport, Storage</b>	<b>15</b>
2.1	Extent of delivery .....	15
2.2	Disposal .....	16
2.2.1	Packing materials .....	16
2.2.2	Returning the device .....	16
2.2.3	Materials used in the units .....	16
<b>3</b>	<b>Description</b>	<b>17</b>
3.1	Construction and principle of the small-parts conveyor units .....	17
3.2	Tuning of the oscillation system .....	17
3.2.1	Principles .....	17
3.2.2	Tuning data .....	18
3.3	Sound pressure level .....	20
<b>4</b>	<b>Installation</b>	<b>21</b>
4.1	Installation of the working unit .....	21
4.1.1	Working unit .....	21
4.1.2	Assembly preparation .....	22
4.1.3	Installation .....	22
4.2	Installation of the small-parts conveyor unit .....	23
4.2.1	Assembly preparation .....	23
4.2.2	Installation .....	23
4.3	Mains connection .....	24
4.3.1	Controller .....	24
4.3.2	Line lengths .....	25
4.3.3	Connection diagrams .....	26
4.3.4	Mains connection .....	28
<b>5</b>	<b>Commissioning</b>	<b>30</b>
<b>6</b>	<b>Maintenance</b>	<b>32</b>
6.1	Regular checks .....	32
6.2	Cleaning .....	33
6.3	Repairs .....	33
<b>7</b>	<b>Troubleshooting</b>	<b>34</b>
<b>8</b>	<b>Index</b>	<b>35</b>

# 1 We are Partners

## 1.1 About this operating manual

### For whom?

This operating manual is intended for

- Installation technicians installing and commissioning the small-parts conveyor drive.
- Engineers installing the controller, the electrical connection to the a.c. mains network and the connection to the small-parts conveyor drive.

All work on the electrical installation must be carried out by qualified personnel (electricians or persons trained in electrical engineering according to IEC 364 and EN 60204-1).

### Additional publications

Supplements to this operating manual:

- Connection diagram for the controller
- Operating manual for the controller
- ATEX-Type Examination Certificate
- Dimension sheet (drawing) of the small-parts conveyor drive

### Definitions

- *Small-parts conveyor drive*: electromagnetic-mechanical unit (vibration system) as it is shown on the frontpage
- *Working unit*: the conveyor unit (trough, tube or rail)
- *Small-parts conveyor unit*: small-parts conveyor drive with the assembled working unit
- *Controller*: the separately shipped controller unit assigned to the small-parts conveyor drive including motor-protective circuit breaker (ATEX) and a varistor protection unit for connecting to the a.c. mains network



#### NOTE!

---

*This operating manual refers only to the small-parts conveyor drives of the type: eKF 1-... (EEx); eKF 6-... (EEx) and eKF 12-... (EEx) in accordance with the type examination certification (BVS .. ATEX ...). For small-parts conveyor drives in standard design there is a separate operating manual.*

---

### Revision date

On the bottom on the right hand side page of this operating manual, the version number tells you the date when the page was last updated.



### Special symbols in this operating manual

Earlier in this manual, you should have learned how we indicate safety notices. If you have any questions about safe work practices regarding small-parts conveyor drives for areas with potentially explosive atmospheres and their environment, you should

---

give us a call! We do not want you to endanger yourself or others just because the possible dangers were not clear to you!

For your convenience and orientation, we use the following special indicators in this operating manual:

- A round bullet indicates a listing of characteristics and conditions.
-  The upward showing thumb tells you to check something, or read a summary.
-  The pointing finger indicates steps that you have to carry out.

## 1.2 Product liability and warranty

The small-parts conveyor drives in special version for areas with potentially explosive atmospheres correspond to the current State of Engineering and have been tested for each of its guaranteed functions prior to delivery. AViTEQ Vibrationstechnik GmbH carries out product and market research to aid further development and continuous improvement. Should malfunctions or failures occur despite these preventative measures, please contact our service department! We guarantee that appropriate measures for the repair of the defect will be taken immediately.

### Conditions of Warranty

We guarantee that the product is free of defects within the scope of the technical product specifications published by AViTEQ Vibrationstechnik GmbH as well as technical specifications provided in this operating manual. No declarations of other product features or claims regarding additional characteristics are provided. AViTEQ Vibrationstechnik GmbH is not liable for the economic efficiency of the product or proper functionality when used for applications other than the purpose defined for the product as specified on the first, left-hand inner page (page 2 / 38) in the front of this operating manual.

### Warranty Exclusions

Customers and third parties must not undertake work inside or otherwise interfere with the product, except the works that are described in this operating manual. Otherwise, liability for devices, persons and other consequential damages of any type to the product specified in the contract and other legal assets is precluded, provided AViTEQ Vibrationstechnik GmbH is not co-responsible. Further the ATEX-authorisation will expire. Entering into or interfering with the equipment also renders any warranty null and void.

AViTEQ Vibrationstechnik GmbH does not accept liability beyond the warranty entitlements stated in our terms of business on which the contract is based. This applies in particular to claims arising from loss of profit or other damage to purchaser/customer assets. This liability limitation does not apply unless the damage was intentional or caused through gross negligence and unless liability for loss of life or limb or loss of health is mandatory. This also does not apply when the purchaser/customer makes a claim for damages based on an incorrect claim of a characteristic or an agreed-upon characteristic. In the event of culpable violation of principle contractual obligations, AViTEQ Vibrationstechnik GmbH is also liable for criminal intent and gross negligence on the part of non-managing employees and for

The  
*General Conditions of Delivery  
Domestic and Abroad*  
of AViTEQ Vibrationstechnik GmbH  
apply in their current version.

mild negligence. In the latter case, this is limited to the contract-typical, judicious, predictable damages. Warranty is excluded in particular when the units are used in environments, for purposes, or connected to power supplies or to control systems that are not suitable for the small-parts conveyor drives for areas with potentially explosive atmospheres or that do not represent the common state of technology. In particular, no warranty is provided for damages caused by unsuitable or incorrect use, incorrect mounting or commissioning by the purchaser/customer or third parties, natural wear, faulty or careless handling or unsuitable operating materials. The same applies for replacement parts, chemical, electrochemical or electrical influences provided they cannot be attributed to AViTEQ Vibrationstechnik GmbH and its employees. Claims made for damages to objects other than that which is specified in the contract, so-called deficiency losses, are limited. In this case, AViTEQ Vibrationstechnik GmbH is liable, regardless of the legal basis, only in the cases of intent, gross negligence on the part of the owner/of its management or managing employee in the event of culpable loss of life or limb or health, in the event of deficiencies which are fraudulently concealed or the absence of which AViTEQ guaranteed, in the event of deficiencies of the delivered object, provided liability is provided in accordance with the product liability law for injury to persons and damages to materials or other special legal requirements.

Likewise, no warranty is provided for damages to conveyance and automation systems which are the result of a malfunction of the product or a textual error in the operating manual. The warranty excludes damages which are the result of accessories not supplied or certified by AViTEQ Vibrationstechnik GmbH. AViTEQ Vibrationstechnik GmbH is not responsible for the violation of patent rights and other titles of third parties outside of the Federal Republic of Germany.

We would like to point out that we are not liable for damage to the product subject to the contract, or for consequential damage to other property, if the damage is caused by non-observation of safety regulations and/or warning notices.

When entering the contract, the purchaser/customer is obliged to point out explicitly if the product is intended for private use and will be used by the purchaser/customer predominantly for this purpose.

The small-parts conveyor drives for areas with potentially explosive atmospheres described in this operating manual must not be operated without consultation and corresponding release by AViTEQ Vibrationstechnik GmbH in the United States of America and other countries where US American laws are applicable.

### 1.3 Operative range

AViTEQ small-parts conveyor drives in special version for areas with potentially explosive atmospheres are designed and intended as units of the unit group II, category 2 and 3 according to EN 50014 for removing, transporting, conveying, measuring out, and distributing small-grained bulk materials and small parts in areas with the risk of explosion by a gas-, a vapour-, a mist- or a dust-air-mixture.

Small-parts conveyor drives are used as components of conveyor and automation plants. Sample applications are...

- general industry use for the transport of, e.g., metal-, plastic- or paint-powder, etc.
- food industry for the transport of, e.g., sugar tea, baking ingredients, cereals, milk powder, spices, muesli, etc.



**NOTE!**

*We carry out experiments for products whose transportation properties are unknown. Give us a call!*

Never use in the following cases:

- *Do not use* with liquids, powder with particle diameters of less than 50  $\mu\text{m}$ , sticky items, items that may jam, bulky items, soft items and fragile items (thin glass)!
- *Do not use* if product temperatures exceed +100°C, or in environmental temperatures below -20°C and above +40°C, or in tropical climate! The units are designed for operation in moderate climate environments.
- *Do not use* in the food industry with standard lacquering. In the case of applications in the food industry a special lacquering is required that is permitted for the food industry.
- *Do not use* if co-existing potentially explosive atmospheres are consisting of a gas-, a vapour-, a mist- **and** a dust-air-mixture (so-called hybrid-mixtures).

#### Connection with the controller

The small-parts conveyor drives in special version for areas with potentially explosive atmospheres must only be operated with the appropriate AViTEQ-controller with a varistor protection unit and a certified (ATEX) motor-protective circuit breaker. A suitable controller exists for every small-parts conveyor drive.

Other control and connection options are not included.



**DANGER!**

*The small-parts conveyor drives in special version for areas with potentially explosive atmospheres are normally delivered without a connection cable and without a cable gland. Select, depending upon your case of application, a connection cable with a suitable cable cross section, permissible in accordance with the standards. The temperature of the connection cable must not exceed a value of +70°C with gas (zone 1 and 2) or dust (zone 21 and 22) at the cable gland and a value of +80°C inside the terminal box at the terminals. Select a connection cable, that is suitable for a maximum temperature of +80°C and ask us in the case of doubt.*



*Only use cable glands with a metric thread, that are permitted for the use in areas with potentially explosive atmospheres for your particular case. The degree of protection of the cable gland must be at least IP65. Further the cable gland must possess a strain relief.*

*Normally the size of the thread for the cable gland is M16x1,5. As special version also the thread size M20x1,5 is possible. Subsequent changing of the thread size or using extensions, reductions and/or intermediate connecting pieces is **not** allowed and results in the invalidity of the type examination certification (BVS.. ATEX...!)*

***Never** open the cover of the terminal box, as long as voltage is present at the terminals inside the terminal box, because this can be an ignition sources and as a result lead to an ignition of a potentially explosive atmosphere consisting of a gas-, a vapour-, a mist- or a dust-air-mixture.*



*Operate the small-parts conveyor drive in special version for areas with potentially explosive atmospheres only with the appropriate controller according to the type examination certification (BVS.. ATEX...). In the case of neglect the type examination certification (BVS.. ATEX...) becomes invalid! Further AViTEQ is exempt from any kind of liability in this case.*

## 1.4 Installation and operating personnel

Persons involved with installation, commissioning, assembly, disassembly, adjustment or maintenance must have read and understood this operating manual in its entirety; in particular the safety notes. If you have any questions, we would be glad to help you!

All work on the electrical installation must be carried out by qualified personnel (electricians or persons trained in electrical engineering according to IEC 364 and EN 60204-1).



*The small-parts conveyor drives in special version for areas with potentially explosive atmospheres are only allowed to be maintained and repaired by AViTEQ Vibrationstechnik GmbH. In the case of non-observance the associated type examination certification (BVS .. ATEX ...) expires. AViTEQ Vibrationstechnik GmbH is not liable for damage to property or person in the case of neglect!*

## 1.5 Safety precautions and responsibilities of the operator

This operating manual is part of the small-parts conveyor drive and must be available to qualified personnel at any time. The following has to be observed:

- Qualified personnel must have appropriate tools and test equipment at their disposal.
- Qualified personnel must be trained in safe work practices and must be familiar with the safety notes.

Prior to installation and/or commissioning, you must be familiar with all details and connection configurations of the small-parts conveyor drive.

- 
- The operator must obtain a local operating permit and observe any conditions relating to it. All requirements for the use of the small-parts conveyor drive in areas with potentially explosive atmospheres must be fulfilled.
  - EC regulations in their current version are to be observed. This applies in particular to EN 60 204-1 regarding machine safety and electrical equipment of machines.
  - The operator may only use the small-parts conveyor drive if it is in perfect condition and in a proper state.

Please observe the following:

- All works on the small-parts conveyor drive require that you observe the safety notes as they are shown in this operating manual.
- Avoid any work practice that compromises safety in relation to the small-parts conveyor drive. **You must not disable any safety mechanisms!**
- Any changes relating to the small-parts conveyor drive that could compromise safety must be reported to the operator immediately.

## 1.6 EC-Directives

The small-parts conveyor drive is not a standalone machine in the sense of the EC Machinery Directive 98/37/EC, and only intended for use together with another machine. Operation is prohibited until it has been established that the machine that is handed to the operator complies with the regulations of the EC directive. The small-parts conveyor drive was built in accordance with these regulations. The associated Manufacturer's Declaration can be found on page 37.

Further the small-parts conveyor drive complies with the regulations of the EC directive 94/9/EC relating to equipment and protective systems for use in areas with potentially explosive atmospheres. The associated Declaration of Conformity can be found on page 36.

## 2 Transport, Storage

Small-parts conveyor drives for areas with potentially explosive atmospheres are delivered in appropriate packaging to ensure that they reach their destination undamaged.

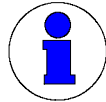

**NOTE!**

*If the packing is visibly damaged in a way that indicates damage to the contents, contact the forwarding agent! In further proceedings, take notice of the General Conditions of Business of the forwarding agent in order not to risk your claim for damages by improperly filled out forms!*

- ☞ **Storage:** Unless special agreements concerning packing and storage have been made, the units, either packed or unpacked, must be stored and transported under „normal“ conditions. This means in enclosed rooms with temperatures between  $-25^{\circ}\text{C}$  and  $+50^{\circ}\text{C}$ , relative humidity not exceed 80%.

When transporting the unpacked small-parts conveyor drive or unit, it is easy to avoid damage by observing the following points:

- ☞ Always grab the small-parts conveyor drive from the underside if you wish to carry it! Never lift it by the working unit!
- ☞ Avoid contact with pointed or sharp (metallic) objects that could damage the protective lacquer coating!
- ☞ Always place the unit onto a secure support base and position, such that the unit cannot tip or fall down!

The dimensions, the weight and the position of the centre of gravity can be found on the separate drawing that exists for every small-parts conveyor drive.



**ATTENTION!**

*Transporting and storing the units under inappropriate conditions may cause permanent damage. Such damage may not be detectable from the outside. AViTEQ does not cover this case in its warranty and is not liable for any consequential damage.*

### 2.1 Extent of delivery

After unpacking, check the delivery note and accompanying documentation to ensure that all the parts have been supplied and are undamaged.

Compare the information on the small-parts conveyor drive type label with the delivery note and order documentation!



**ATTENTION!**

*Destruction of small-parts conveyor drive and controller possible if the units don't match! Only operate units that belong together and observe the information in the associated type examination certification (BVS .. ATEX ...).*

*The motor-protective circuit breaker has to be set to the value of the rated current (nominal current) of the small-parts conveyor drive, as it is shown on the type label of the small-parts conveyor drive! Check this prior to first commissioning and correct, if necessary, the setting, if it isn't correct.*

In the case of applications in the food industry, please check, if the small-parts conveyor drive was delivered with a special lacquering.

---

## 2.2 Disposal

### 2.2.1 Packing materials

The following materials are used by AViTEQ for delivering the small-parts conveyor drives, depending on the type of transport:

- Polyethylene foil (PE) for device protection
- Corrugated cardboard for outer and inner packing
- Wooden cases for outer packing
- Paper shavings as filler material
- Styrofoam (Flo-Pack) as filler and cushioning material

All packing materials should be disposed of in accordance with local regulations of the delivery destination.



Cardboard containers and paper packing tapes can be recycled within the RESY Disposal and Re-utilisation System. Where used, packaging foil, packing tapes, and foam foils are made from polyethylene (PE), the CFC-free cushions are usually made from polystyrene foam (PS). These packing materials consist of pure hydrocarbons and can thus be recycled.

In special cases, we use steel packing bands and wooden cases free of chemical treatment.

### 2.2.2 Returning the device

AViTEQ Vibrationstechnik GmbH will accept without charge small-parts conveyor drives, type: eKF... (EEx), that have been delivered in 2003 or later when delivered shipping paid to AViTEQ Vibrationstechnik GmbH, D-65795 Hattersheim-Eddersheim, Germany.

AViTEQ guarantees for a professional disposal. Therefore the small-parts conveyor drives have to be free of product arrears and pollutants. Otherwise AViTEQ is justified to refuse the acceptance of the drive.

### 2.2.3 Materials used in the units

In case of disposal by the customer, and when exchanging components, the current local waste and disposal regulations apply and should be observed. We accept no responsibility for improperly disposed of parts and components!

- The regulations for the disposal of electronic parts and components apply to the disposal of the controller.
- The power semiconductors used (triacs and diode modules) do not contain beryllium.



**NOTE!**

---

*More detailed information on the materials used is available from us on request. In case of doubt, please do make use of our recycling service.*

---

## 3 Description

### 3.1 Construction and principle of the small-parts conveyor units

AViTEQ small-parts conveyor drives are used as drives for small-parts conveyor units. A small-parts conveyor unit consists of at least the following components:

- Small-parts conveyor drive
- Working unit (trough, tube or rail)
- Controller

Further a hopper may be part of the unit.

The construction concept of the small-parts conveyor drive is shown in the figure below.

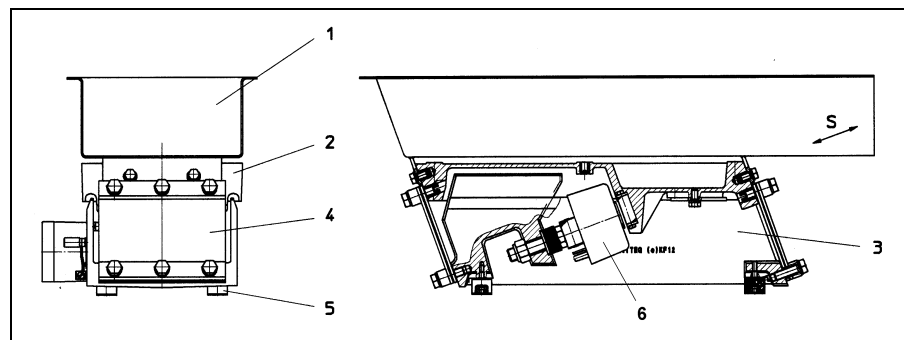

Figure 3-1 Construction principle of the small-parts conveyor unit

The small-parts conveyor drive is a two-mass oscillation system and is, among other things, made up of the main components: base plate (2), leaf springs (4), electromagnet (6) and lower part (3).

The electromagnet (6) generates a straight-path upwardly oscillation motion. The working unit (1), that is mounted to the base plate (2), transmits the oscillation motion to the transported material. Together the base plate and the working unit form one mass unit within the oscillation system. The lower part (3) represents the counter-mass. Both masses are connected by leaf springs (4). Rubber feet (5) support the oscillation system to its environment.

Each voltage cycle exerts a pulling force on the electromagnet (6). Depending on the type of the small-parts conveyor drive the unit oscillates with 3,000 or 6,000 oscillations per minute at a 50Hz-mains. By changing the voltage from the controller, the working stroke and hence the throughput may be adjusted during operation from close to 0 to 100 %.

### 3.2 Tuning of the oscillation system

#### 3.2.1 Principles

Vibration drives are spring-mass oscillation systems that exploit the resonance of the oscillation system. If the system is stimulated, it continues to oscillate with its natural frequency, with a decaying amplitude depending on its attenuation properties.



If a sinusoidal force acts on this system with a frequency different from the natural frequency (vibration frequency or drive frequency), the entire system will no longer oscillate at its natural frequency (resonance frequency), but will follow the rhythm of the force exerted on it (forced oscillation).

The closer the natural and the vibration frequency are, the larger the working stroke. However, for electromagnetic vibration drives, operation in the immediate vicinity of the natural frequency is critical, because retroactivities of the transported material like attenuation and coupling effects may have negative effects. For a stable operation of the oscillation system, a well-defined distance from the natural frequency is required. In this case, the natural frequency may be lower or higher than the vibration frequency.

AViTEQ small-parts conveyor drives for areas with potentially explosive atmospheres, as described in this manual, always work in sub-critical operation. The natural frequency of the oscillation system is greater than the vibration frequency.

### 3.2.2 Tuning data

Before delivery, small-parts conveyor drives without working units are factory-tuned for a specified working weight that is named „G<sub>n</sub>“ on the type label.

 AViTEQ Vibrations-technik GmbH D-65795 Hattersheim-Eddersheim www.aviteq.de			
 BVS 03 ATEX ... II 2 G EEx e IIB T4 II 2 D IP65 T 115°C	Year 2003		
Type eKF12-2-... (EEx)	3000 min <sup>-1</sup>	$l_a/l_b$	...
Serial no. ...	...	$l_e >$	... min
...	V ... A	G <sub>n</sub> ... kg	...
DIN VDE 0580	50 Hz	Made in Germany	

If the user installs a lower working weight, additional weights must be attached to the drives base plate until the combined mass reaches the given working weight. Else, if the user installs a higher working weight, the original distance from the natural frequency must be restored by changing the leaf spring arrangement. This is only allowed by AViTEQ!



*Changes of the air gap, the spring rate, the tightening torque of the spring mounting screws, installation without rubber feet and deviations from the intended working weight (see type label) are not allowed and results in the invalidity of the type examination certification (BVS.. ATEX...), because this may lead to excessive heating of the drive, to short circuits between electromagnet windings, and eventually to the destruction of the drive.*

*We always recommend our customers to send in the working unit, so that AViTEQ can carry out the exact tuning of the small-parts conveyor drive.*

When constructing your own working unit, you should ensure that sideway folding of the (trough) edges or other stiffening measures are used to achieve sufficient stiffness of the working unit if larger dimensions, thin metal sheets, or low side walls are used.

The technical data of the drives are shown in the following tables:

Drive	eKF 1-... (EEx)	eKF 6-... (EEx)	eKF12-... (EEx)	Remarks
<b>Mains frequency: 50 Hz</b>				
Working weight (ideal)	1.5 kg	3.0 kg	6.0 kg	Standard adjustment
Working weight (max.)	3.5 kg	7.0 kg	20.0 kg	Maximum value, tuning only allowed to be carried out by AViTEQ!
Air gap	~ 1.0 mm	~ 2.5 mm	~ 3.5 mm	
Natural frequency (ideal)	105...106 Hz	57...58 Hz	57...58 Hz	
Natural frequency (max.)	103...108 Hz	55...60 Hz	55...60 Hz	
Nominal current (max.) with...				
380 V nominal voltage	-	-	1.27 A	
240 V nominal voltage	0.20 A	0.75 A	2.20 A	
220 V nominal voltage	0.20 A	0.75 A	2.20 A	
110 V nominal voltage	0.40 A	1.40 A	4.40 A	
Vibrator voltage with...				
380 V nominal voltage	-	-	380 V	Only use a true RMS meter for the measurement because of the non-sinusoidal voltage signal!
240 V nominal voltage	210 V	210 V	210 V	
220 V nominal voltage	210 V	210 V	210 V	
110 V nominal voltage	100 V	100 V	100 V	
Collision voltage with...				
380 V nominal voltage	-	-	390 V	Only use a true RMS meter for the measurement because of the non-sinusoidal voltage signal!
240 V nominal voltage	216 V	216 V	216 V	
220 V nominal voltage	216 V	216 V	216 V	
110 V nominal voltage	105 V	105 V	105 V	
Working stroke with associated controller	0.5...0.6 mm	1.4...1.5 mm	1.4...1.5 mm	
Oscillation rate	6,000 min <sup>-1</sup>	3,000 min <sup>-1</sup>	3,000 min <sup>-1</sup>	

Table 3-2 Operating data, 50 Hz-net

Drive	eKF 1-... (EEx)	eKF 6-... (EEx)	eKF12-... (EEx)	Remarks
<b>Mains frequency: 60 Hz</b>				
Working weight (ideal)	1.5 kg	3.0 kg	6.0 kg	Standard adjustment
Working weight (max.)	3.5 kg	7.0 kg	20.0 kg	Maximum value, tuning only allowed to be carried out by AViTEQ!
Air gap	~ 0.9 mm	~ 2.4 mm	~ 2.9 mm	
Natural frequency (ideal)	123...124 Hz	64...65 Hz	64...65 Hz	
Natural frequency (max.)	123...126 Hz	63...68 Hz	63...68 Hz	
Nominal current (max.) with...				
380 V nominal voltage	-	-	1.27 A	
220 V nominal voltage	0.20 A	0.70 A	2.20 A	
110 V nominal voltage	0.40 A	1.30 A	4.40 A	
Vibrator voltage with...				
380 V nominal voltage	-	-	365 V	Only use a true RMS meter for the measurement because of the non-sinusoidal voltage signal!
220 V nominal voltage	210 V	210 V	210 V	
110 V nominal voltage	100 V	100 V	100 V	
Collision voltage with...				
380 V nominal voltage	-	-	375 V	Only use a true RMS meter for the measurement because of the non-sinusoidal voltage signal!
220 V nominal voltage	216 V	216 V	216 V	
110 V nominal voltage	105 V	105 V	105 V	
Working stroke with associated controller	0.5...0.6 mm	1.2...1.4 mm	1.2...1.4 mm	
Oscillation rate	7,200 min <sup>-1</sup>	3,600 min <sup>-1</sup>	3,600 min <sup>-1</sup>	

Table 3-3 Operating data, 60 Hz-net

---

### **3.3 Sound pressure level**

The small-parts conveyor drive generates a sound pressure level of less than 70 dB(A) without considering the working unit or the transported material. Depending on the construction of the working unit and the acoustic properties of the material transported, the sound pressure level of the operational small-parts conveyor unit may exceed 70 dB(A). It is the operator's responsibility to ensure adherence to the sound pressure level permitted by means of suitable noise protection measures!

## 4 Installation

### 4.1 Installation of the working unit



**ATTENTION!**

For making the working unit (trough, tube or rail) all materials are allowed **except** aluminium alloys with a magnesium part by weight greater than 6% and plastic with a surface resistivity greater than  $10^9$  Ohm.



**NOTE!**

If the small-parts conveyor drive was delivered by AViTEQ complete with the working unit (trough, tube or rail) assembled, you may skip ahead to chapter 4.2 „Installation of the small-parts conveyor unit“ on page 23 now.

#### 4.1.1 Working unit

If you want to build your own working unit, please observe the following advices:

- ☞ The trough has to be stiff to avoid bending. In the case of large lengths/widths and low side walls, sideways folding of the edges or other stiffening measures may be required to achieve this. If required, ribs or rails have to be attached. However, this must not interfere with the attachment of the trough.
- ☞ Operating noise: the small-parts conveyor drive generates a sound pressure level of less than 70 dB(A) without considering the working unit or the transported material.



**NOTE!**

Depending on the construction of the working unit and the acoustic properties of the material transported, the sound pressure level of the operational small-parts conveyor unit may exceed 70 dB(A). It is the operator's responsibility to ensure adherence to the sound pressure level permitted by means of suitable noise protection measures!

- ☞ The centre of gravity of the working unit (trough, tube rail) should be within the front section (outlet side) of the small-parts conveyor drive.
- ☞ When placing the mounting holes, use the information in the AViTEQ leaflet „small-parts conveyor units“. Do not drill any additional holes into the small-parts conveyor drive! Only use the threaded holes on the small-parts conveyor drive!
- ☞ For correct alignment of the oscillation system, it is best to inform AViTEQ about the actual working weight (not including transported material) when ordering the small-parts conveyor drive!



**NOTE!**

It is possible to run longer transport systems (trough, tube or rail) with several successive small-parts conveyor drives. Ask AViTEQ about it!

## 4.1.2 Assembly preparation

- ☞ Put the small-parts conveyor drive onto a solid and flat surface!



*Inadequate installation may cause the small-parts conveyor drive to fall down possibly causing injuries or lead to an ignition spark. Take appropriate steps to ensure that the small-parts conveyor drive cannot fall down!*

- ☞ Keep the mounting screws ready for the working unit. Choose screws with a bolt quality of 8.8 and ensure that the screws have the correct length!
- ☞ The controller must be separated from the mains if it has already been connected to the small-parts conveyor drive.

## 4.1.3 Installation

<b>AVITEQ</b> AVITEQ Vibrationstechnik GmbH D-65795 Hattersheim-Eddersheim www.aviteq.de	
BVS 03 ATEX II 2 G EEx e IIB T4 II 2 D IP65	Year 2003 T 115°C CE 0158
Type eKF12-2-... (EEx)	3000 min <sup>-1</sup> k <sub>a</sub> /N ...
Serial no. ...	G <sub>n</sub> ... kg f <sub>e</sub> > ... min
... V ... A DIN VDE 0580 50 Hz	Made in Germany

- ☞ Weigh the working unit (trough, tube or rail) without the transported material.
- ☞ Compare the weight measured with the weight „G<sub>n</sub>“ shown on the type label on the small-parts conveyor drive (see figure left).
- ☞ If the weight of the working unit is smaller, you will need to add additional weight (e.g., spacer plates) to reach the specified working weight. Such additional weight can be covered by AVITEQ. If the weight of the working unit exceeds the specified working weight, the small-parts conveyor drive **must** be re-tuned by AVITEQ.



*Collision mode due to excessive working weight! Therefore deviations from the specified working weight are not allowed and results in the invalidity of the type examination certification (BVS.. ATEX...), because this may lead to excessive heating of the drive, to short circuits between electromagnet windings, and eventually to the destruction of the drive.*



*Low working weight results in low throughput! Do not commission the unit until the working weight (without transported material) corresponds to the specification on the type label!*

- ☞ Mount the working unit and if required, the additional weights (see figure 4-2) by screw joint onto the small-parts conveyor drive. Depending on the construction of the working unit, the fixing is carried out from above or frontal. The appropriate tightening torque for the screws is shown in table 4-1 below.

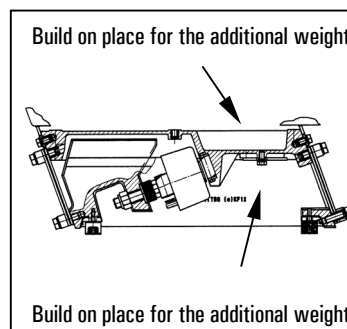

Figure 4-2 Build on place for the additional weight

Screw size	Tightening torque for screws (quality 8.8)
M5	5 Nm
M6	8 Nm
M8	20 Nm

Table 4-1  
Tightening torques for screws

- ☞ Ensure that the attachment screws are not too long! If they are, the working unit may not be able to be attached, or the screws ends pointing to the inside restrict the movement of the upper part (base plate) of the small-parts conveyor drive.
- ☞ Do not drill holes into the bottom of the trough! Protruding screw heads obstruct the product flow.

## 4.2 Installation of the small-parts conveyor unit



**NOTE!**

*AViTEQ also delivers completed units, consisting of the small-parts conveyor drive, working unit, hopper and a appropriate base plate. In this case only the fixing of the base plate with the support structure is required. No additional rubber feet are required.*

---

### 4.2.1 Assembly preparation

- ☞ Put the small-parts conveyor drive onto a solid and flat surface!



**DANGER!**

*Inadequate installation may cause the small-parts conveyor drive to fall down possibly causing injuries or lead to an ignition spark. Take appropriate steps to ensure that the small-parts conveyor drive cannot fall down!*

---

- ☞ Keep the mounting screws ready for the small-parts conveyor drive. Choose screws with a bolt quality of 8.8 and ensure that the screws have the correct length (see table 4-3 on page 24)!
- ☞ The controller must be separated from the mains if it has already been connected to the small-parts conveyor drive.

### 4.2.2 Installation

- ☞ Position the small-parts conveyor drive at the intended assembly place. Before you mark the drilling holes, check that the working unit can vibrate freely without striking against neighbouring conveyor components. The distance depends on the working stroke, which will be adjusted later.



**NOTE!**

*In the case of working units with input and output nozzle, the bellow used must not impede free vibration of the unit. Observe appropriate bellow length and flexibility!*

*Further the bellows used must be suitable for the present application and for areas with potentially explosive atmospheres.*

---

- ☞ Drill holes and make sure, that you do not damage the rubber feet if you leave the unit on the support structure during drilling!
- ☞ Fix the rubber feet to the support structure. The appropriate tightening torques for the screws are shown in table 4-3 on the following page. Do not exceed the permissible tightening torques as this may result in damage to the rubber foot concerned.

Drive	Screw size	Tightening torque for screws	Minimum and maximum screw length inside rubber foot
eKF 1-... (EEx)	M4	2,4 Nm	3...4 mm
eKF 6-... (EEx)	M6	8,0 Nm	3...5 mm
eKF 12-... (EEx)	M6	8,0 Nm	3...5 mm

Table 4-3 Tightening torques for screws and screw length inside the rubber feet



*Insufficient attachment of the small-parts conveyor unit! Ensure that the attachment screws have the correct length! The screws must not reach the bottom of the mould in the feet, as this prevents safe attachment of the small-parts conveyor drive.*

*Insufficient attachment leads to a relative motion between the lower part and the support construction and can result in the destruction of the rubber feet, and further in the formation of ignition sources as a result of collision mode.*

- ☞ Provide for a potential equalization between the small-parts conveyor drive and the support structure by an appropriate grounding. Use one of the existing grounding terminals at the lower part of the small-parts conveyor drive.

## 4.3 Mains connection

### 4.3.1 Controller



*Small-parts conveyor drives in special version for areas with potentially explosive atmospheres must only be operated with the appropriate AViTEQ-controller that is certificated for this case. The controller itself **must not** be installed in areas with potentially explosive atmospheres, and, according to the type examination certification (BVS.. ATEX...), has to be completed with a motor-protective circuit breaker with a ATEX-Certification and a varistor protection unit for every small-parts conveyor drive. In the case of neglect AViTEQ is not liable for the consequences!*

***In particular it is prohibited to operate the small-parts conveyor drive with a frequency converter.***

*Small-parts conveyor drives in normal version without an ATEX-type examination certification **must not** be operated in areas with potentially explosive atmospheres consisting of a gas-, a vapour-, a mist- or a dust-air-mixture.*

Two type series of AViTEQ controllers with different characteristics are applicable and can be designated:

- **SRA(E)...**, series with voltage regulation for nominal currents up to 6,0 A with soft start. Mains voltage fluctuations are compensated and are almost without an effect on the conveyor capability. Optional the controller can be delivered with a level scanning system / part overflow controller. Controllers with a level scanning system / part overflow controller are specially designed for linking several small-parts conveyor units and/or bowl feeders.



*For using the level scanning system or the part overflow controller a appropriate sensor is needed, that is permitted to be used in areas with potentially explosive atmospheres and therefore must have an appropriate ATEX-authorisation for the present area of application.*

*Unless the sensor isn't part of the AViTEQ supply, AViTEQ isn't responsible for the sensor selected and therefore further isn't liable for damages that result out of incorrect selection and an incorrect case of operation of a sensor that isn't permitted for the case of operation..*

---

- **SC(E)...**, series with voltage regulation for nominal currents up to 15,0 A with soft start.

The controllers can optionally be delivered in the following versions:

- **Cabinet unit** (IP54), controller in a closed housing. Depending on the type of controller, the terminals are designed pluggable and a potentiometer and a switch (On/Off) are integrated on the front plate. Delivered with an appropriate operating manual.
- **Panel mounting unit** (IP00 or IP20), controller for installation in switching cabinets or control cases. Depending on the type, the fixing of the controller results from mounting onto a top hat rail or bolting together with a subplate. Delivered with an appropriate potentiometer (delivered loose) and operating manual.

#### 4.3.2 Line lengths

When you install the cable between the small-parts conveyor drive and the controller, please observe the following:

- ☞ The cable length must not exceed **40 m**,
- ☞ Only use cable whose insulation suits the special environmental conditions and that are suitable for areas with potentially explosive atmospheres. For pharmaceutical and food processing applications, you must further choose sterilizable insulations.
- ☞ In the proximity of the small-parts conveyor drive, run the cable in such a way that contact with vibrating parts is impossible.



*Short circuits and electric shock may result if insulation is damaged by rubbing! Connecting cables must **never** come in contact with vibrating parts – otherwise, the insulation may get damaged. Run the cables in a way that excludes this danger!*

---

- ☞ Avoid cable loops! Shorten cables if required.

### 4.3.3 Connection diagrams

Depending on the application a single small-parts conveyor drive (s. figure 4-4) or up to 4 small-parts conveyor drives (s. figure 4-5) can be operated with a single controller.

Also the connection of a sensor with a AViTEQ controller of the type eSRA... (EEEx) in special version with level scanning system or part overflow controller is possible.



*Unless the sensor isn't part of the AViTEQ supply, AViTEQ isn't responsible for the sensor selected and therefore further isn't liable for damages that result out of incorrect selection and an incorrect case of operation of a sensor that isn't permitted for the case of operation.*

For single drives the wiring has to be carried out as shown in figure 4-5 below.

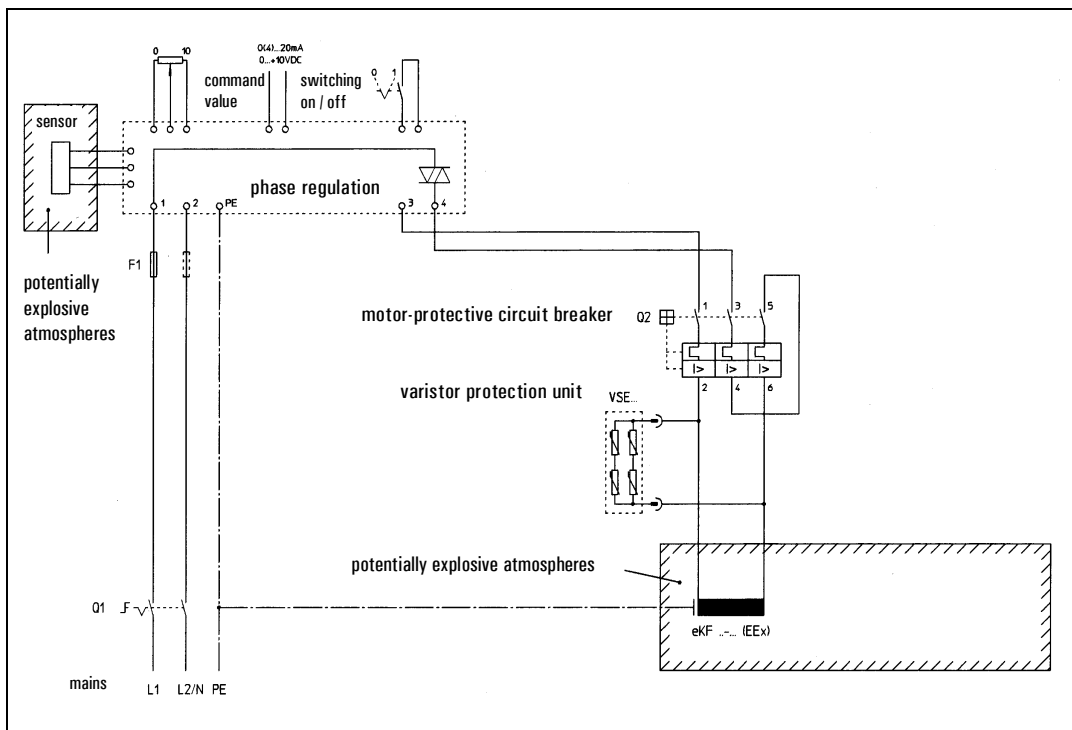

Figure 4-4 Connection diagram, single drive



*Unsuitable controllers, operation without controller or operation with the incorrect mains voltage/frequency could result in damage to the small-parts conveyor drive and are not allowed. Ensure that the connected loads are correct and compare them with the device type labels! Further observe the information in the associated type examination certification (BVS .. ATEX ...).*

*The motor-protective circuit breaker has to be set to the value of the rated current (nominal current) of the small-parts conveyor drive, as it is shown on the the type label of the small-parts conveyor drive! Check this prior to first commissioning and correct, if necessary, the setting, if it isn't correct.*



**ATTENTION!**

*It is totally prohibited that the current consumption of the small-parts conveyor drive exceeds the value of the nominal current specified on the type label, because this leads to temperatures that exceed the respective temperature class. In this case the associated type examination certification (BVS.. ATEX...) becomes invalid and further this may lead to the destruction of the small-parts conveyor drive.*

If several small-parts conveyor drives (multiple drives) are operated with a common controller the wiring has to be carried out as shown in figure 4-5 below.

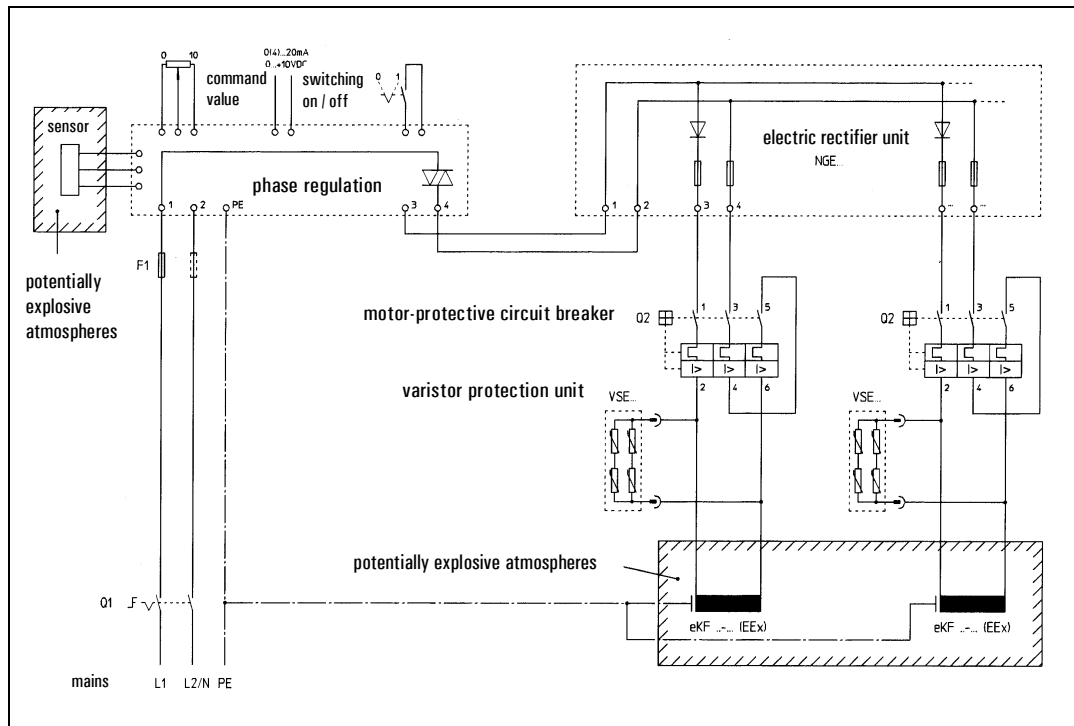

Figure 4-5 Connection diagram, multiple drives



**ATTENTION!**

***Every small-parts conveyor drive must be operated with a separate motor-protective circuit breaker! It is not allowed to add up the currents of several small-parts conveyor drives and then operate them with a common motor-protective circuit breaker!***

*In particular observe the following data on the type label:  $I_A/I_N$  – Ratio between the pull-in current  $I_A$  and the rated current (nominal current)  $I_N$  and the time  $t_E$  – time period in which the coil of the electromagnet, as a result of the pull-in current, warms up from the end-temperature during rating mode with an ambient temperature of +40°C to the limit temperature.*

*For every small-parts conveyor drive a AViTEQ varistor protection unit (VSE...) is required!*

*With multiple drives (s. figure 4-5) further a AViTEQ electric rectifier unit (NGE...) is required!*

---

#### 4.3.4 Mains connection



*The small-parts conveyor drives in special version for areas with potentially explosive atmospheres are normally delivered without a connection cable and without a cable gland. Select, depending upon your case of application, a connection cable with a suitable cable cross section, permissible in accordance with the standards. The temperature of the connection cable must not exceed a value of +70°C with gas (zone 1 and 2) or dust (zone 21 and 22) at the cable gland and a value of +80°C inside the terminal box at the terminals. Select a connection cable, that is suitable for a maximum temperature of +80°C and ask us in the case of doubt.*

*Only use cable glands with a metric thread, that are permitted for the use in areas with potentially explosive atmospheres for your particular case. The degree of protection of the cable gland must be at least IP65. Further the cable gland must possess a strain relief.*

*Normally the size of the thread for the cable gland is M16x1,5. As special version also the thread size M20x1,5 is possible. Subsequent changing of the thread size or using extensions, reductions and/or intermediate connecting pieces is **not** allowed and results in the invalidity of the type examination certification (BVS.. ATEX...!)*

***Never** open the cover of the terminal box, as long as voltage is present at the terminals inside the terminal box, because this can be an ignition sources and as a result lead to an ignition of a potentially explosive atmosphere consisting of a gas-, a vapour-, a mist- or a dust-air-mixture.*



*When the unit is connected to the mains, a lethal voltage is present inside the controller and the terminal box of the small-parts conveyor drive. Touching electrically live components can be lethal! Before switching on mains power, ensure that no live parts can be touched and the cover of the terminal box is closed!*



**NOTE!**

*Depending on the number of small-parts conveyor drives, type: eKF... (EEx) for areas with potentially explosive atmospheres, that are operated with a AViTEQ-controller, there is a connection diagram, that is part of this operating manual and is shown in chapter 4.3.3 (connection diagrams). This connection diagram **must** be observed compellently. The wiring has to be carried out according to the connection diagram. Especially this has to be observed, if the controller is delivered as a cabinet mounting unit, that is built-in into a cabinet by the customer.*

*In the case of non-observance the associated type examination certification (BVS .. ATEX ...) expires. AViTEQ Vibrationstechnik GmbH is not liable for damage to property or person in the case of neglect!*

At first choose an adequate connection cable and a appropriate cable gland. While choosing the cable, please observe that there is a relative movement between the terminal box at the small-parts conveyor drive and the support structure during operation.



**NOTE!**

*The threaded hole at the terminal box for the cable gland is closed with a blind plug by AViTEQ. Remove this blind plug before assembling the cable gland. Do **not** use this blind plug in areas with potentially explosive atmospheres, because the blind plug isn't suitable for such areas.*

Connect the connection cable as shown below (figure 4-6).

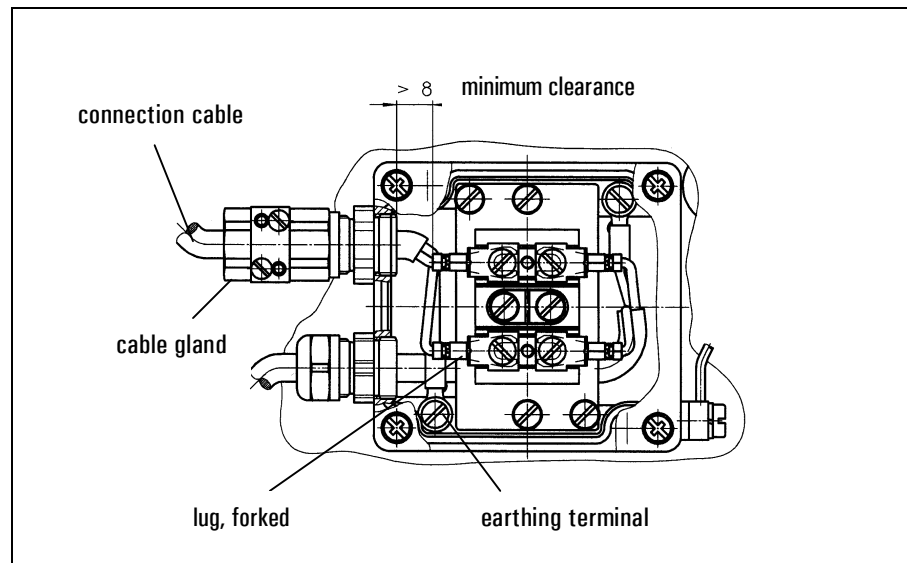

Figure 4-6 Elektrical connection eKF... (EEx) (terminal box on the right side)

Connect the conductors L1 and L2 or N to the terminal board by using (non-)isolated lugs (forked). The green-yellow wire has to be connected to the earthing terminal with a lug (closed), as shown in figure 4-6 above. Tighten all screws well, so that they cannot untighten during operation.



**ATTENTION!**

*Observe while carrying out the connection, that between the net-potential-prominent terminals and the associated lugs (forked) and the inner wall and the cable gland a minimum clearance of 8 mm must exist! This minimum clearance of 8 mm must not be fallen below.*

*In the case of non-observance the associated type examination certification (BVS .. ATEX ...) expires. AViTEQ Vibrationstechnik GmbH is not liable for damage to property or person in the case of neglect!*

---

## 5 Commissioning



**DANGER!**

*Parts that collide with other parts can lead to ignition sources. Before first commissioning make sure that the working unit can oscillate without colliding with other parts and that all screws are tightened correctly.*

*The magnet system is coated with a special dark impact-protection lacquer, that anticipates the formation of ignition sparks. However, a so-called collision mode is **not permitted!** In the case of visible damage of the impact-protection lacquer in the area of the electromagnet, the small-parts conveyor drive in special version for areas with potentially explosive atmospheres is not allowed to be operated and has to be sent to AVITEQ for being repaired!*

Prior to the first commissioning all assembly works have to be carried out, as they are described in the previous chapter.

AVITEQ delivers small-parts conveyor drives for areas with potentially explosive atmospheres including the appropriate controllers. Before commissioning, please check that the small-parts conveyor drive is only operated with a AVITEQ-controller!



**DANGER!**

*Small-parts conveyor drives in special version for areas with potentially explosive atmospheres must only be operated with the appropriate AVITEQ-controller that is certificated for this case. The controller itself **must not** be installed in areas with potentially explosive atmospheres, and, according to the type examination certification (BVS.. ATEX...), has to be completed with a motor-protective circuit breaker with a ATEX-Certification and a varistor protection unit for every small-parts conveyor drive. In the case of neglect AVITEQ is not liable for the consequences!*

***In particular it is prohibited to operate the small-parts conveyor drive with a frequency converter.***

*Small-parts conveyor drives in normal version without an ATEX-type examination certification **must not** be operated in areas with potentially explosive atmospheres consisting of a gas-, a vapour-, a mist- or a dust-air-mixture.*



**ATTENTION!**

*Unsuitable controllers, operation without controller or operation with the incorrect mains voltage/frequency could result in damage to the small-parts conveyor drive and are not allowed. Ensure that the connected loads are correct and compare them with the device type labels! Further observe the information in the associated type examination certification (BVS .. ATEX ...).*

*The motor-protective circuit breaker has to be set to the value of the rated current (nominal current) of the small-parts conveyor drive, as it is shown on the the type label of the small-parts conveyor drive! Check this prior to first commissioning and correct, if necessary, the setting, if it isn't correct.*



**NOTE!**

*For anticipating the formation of ignition sparks by collision of parts of the magnetic system the armature is coated with a special dark impact-protection lacquer. Further the electromagnet is coated with a conductible lacquer. In the case of visible damage of the impact-protection lacquer or the conductible lacquer in the area of the electromagnet, the small-parts conveyor drive in special version for areas with potentially explosive atmospheres is not allowed to be operated and has to be sent to AVITEQ for being repaired!*

The commissioning procedure must be carried out using the lowest working stroke: Turn the vibration-width adjuster (potentiometer) on the controller counter clockwise till you reach the end stop (scale value of 0) or, if you use an external command value, set the lowest command value. Now switch on the controller.



**NOTE!**

*The commissioning process is carried out at a low working stroke in order to be able to detect any damage caused by assembly errors or the vibration behaviour of the entire vibration conveyor device which is undetected at this point. Example: The working unit collides with neighbouring conveyor components or works in collision mode.*

---

Listen for any *hammering* noises that indicate the *collision mode*.

Slowly increase the working stroke by gradually turning the vibration-width adjuster (potentiometer) or by increasing the external command value, until the maximum value has been reached.

If hammering noises or resonances of the working unit or the support structure occur, switch off the unit and check the cause. By measuring the current and the voltage on the terminals of the controller, you can check the appropriate values. The maximum allowed vibrator voltage, that is shown in the tables 3-2 and 3-3 on page 19 for the respective nominal voltage and mains frequency, **must** not be exceeded!



**DANGER!**

*Short circuit or danger of electrocution during the following measurements! Observe the safety regulations when measuring voltage-carrying components! Take appropriate measures to prevent contact with voltage-carrying components.*

---



**NOTE!**

*Only use meters which display the root mean square value for measuring the voltage and the current (moving iron instrument or „true RMS“). Other measuring devices would not produce relevant measurements when measuring the non-sinusoidal voltage or current curve. For digital measuring devices, select a measuring range of  $\geq 750\text{ V}$  to avoid incorrect measurements due to the crest factor!*

---

The current that is shown on the type label must not be exceeded!

If no problems appeared, please check the function of the small-parts conveyor unit with the appropriate transported material for completing the commissioning: Is the material transported uniformly? Measure whether the required throughput is achieved!

Did problems appear while commissioning or do you have any questions, give us a call. We'll be glad to help you.

## 6 Maintenance



*Before carrying out any inspection works, the small-parts conveyor drive must be disconnected from mains and protected against reconnecting. Check, that no voltage is present! Further check, if the surface temperature is less than +50°C, otherwise the surface temperature may lead to burns of the skin!*

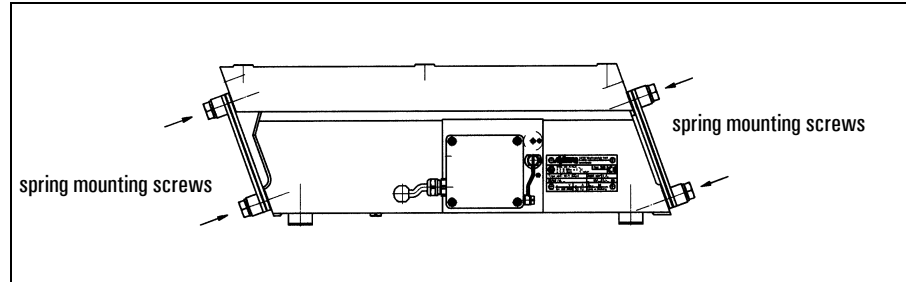

Figure 6-1 Spring mounting screws

It is prohibited to loosen the spring mounting screws (see figure 6-1) or to alter their tightening torque! Please observe this.



*Changes of the air gap, the spring rate, the tightening torque of the spring mounting screws, installation without rubber feet and deviations from the intended working weight (see type label) are **not** allowed and results in the invalidity of the type examination certification (BVS.. ATEX...), because this may lead to excessive heating of the drive, to short circuits between electromagnet windings, and eventually to the destruction of the drive.*

### 6.1 Regular checks

We recommend to carry out the following checks in regular intervals as they are shown below:

Test intervals	Checks
2 operating hours after the first commissioning	<ul style="list-style-type: none"> <li>- Check screw connections (working unit/drive)</li> <li>- Check, if connection cable doesn't swing</li> <li>- Check, if connection cable shows visible damages</li> <li>- Check noise development</li> <li>- Check, that no deposits are existing (working unit/hopper)</li> </ul>
24 operating hours after the first commissioning	<ul style="list-style-type: none"> <li>- Check screw connections (working unit/drive)</li> <li>- Check, if connection cable doesn't swing</li> <li>- Check, if connection cable shows visible damages</li> <li>- Check noise development</li> <li>- Check, that no deposits are existing (working unit/hopper)</li> <li>- Check condition of the rubber feet</li> <li>- Check condition of the working unit</li> </ul>
weekly	<ul style="list-style-type: none"> <li>- Check, if connection cable doesn't swing</li> <li>- Check, if connection cable shows visible damages</li> <li>- Check noise development</li> <li>- Check, that no deposits are existing (working unit/hopper)</li> </ul>
monthly	<ul style="list-style-type: none"> <li>- Check screw connections (working unit/drive)</li> </ul>
half-yearly	<ul style="list-style-type: none"> <li>- Check condition of the rubber feet</li> <li>- Check condition of the working unit</li> </ul>

Table 6-2 Regular checks

## 6.2 Cleaning

Depending on the environmental condition and the properties of the material transported, the components of the small-parts conveyor unit, in particular the working unit, will be subject to varying degrees of contamination.

Check the contamination level on regular basis. Initially, check on a weekly basis, thereafter check in intervals that you determine based on the requirements.

If the contamination is significant enough to impair the throughput, or there is a layer of dirt on the small-parts conveyor drive, it must be cleaned. As cleaning methods, alongside mechanical methods (hand brush e.g.), pressurized air and water with and without chemical cleansing agents are permitted.

Proceed thereby as follows:

- ☞ Switch off the power to the drive before any cleaning operation!
- ☞ Select the appropriate method! If applicable, follow the guidelines for the use of pressurized air, water and cleaning solvents that apply to the installation site! Also observe the degree of protection (IP65) and take appropriate steps to avoid water intrusion into the terminal box.
- ☞ Only use cleaning solvents with a pH value of 7 or less!
- ☞ Do not use cleaning solvents containing chlorine!
- ☞ When cleaning with compressed air, observe any in-house regulations regarding dust!



---

*Detachment of paintwork and contamination of the transported material! Do not use aggressive agents that could damage the paintwork! In the food processing industry, only permitted cleaning agents and solvents may be used. Do not use cleaning agents that may attack the plastic insulation of cables and cable glands!*

---

- ☞ Remove all residues of transported material and cleaning agent after cleaning!

## 6.3 Repairs

In the event of damage, please send the small-parts conveyor drive back to AViTEQ Vibrationstechnik GmbH, D-65795 Hattersheim-Eddersheim, Germany for being repaired. Self-repairs are **prohibited**.



---

*It is absolutely forbidden to carry out maintenance work. The small-parts conveyor drives in special version for areas with potentially explosive atmospheres are only allowed to be maintained and repaired by AViTEQ Vibrationstechnik GmbH.*

*In the case of non-observance the associated type examination certification (BVS .. ATEX ...) expires. AViTEQ Vibrationstechnik GmbH is not liable for damage to property or person in the case of neglect!*

*The only work, that is allowed, is the electrical connection with opening the cover of the terminal box and the mounting of the working unit..*

---

## 7 Troubleshooting

In the following table you will find information regarding possible faults which could occur during installation or during operation.

	Fault	Cause(s)	Remedy
①	Small-parts conveyor drive does not function	No mains voltage	Check fuse(s) and the supply line(s)
		Units (controller, small-parts conveyor drive) defect	Please send the units to AViTEQ Vibrationstechnik GmbH, we will check and if possible repair the units
②	Release of the motor-protective circuit breaker	Motor-protective circuit breaker has the wrong adjustment	Observe the current shown on the type label on the small-parts conveyor drive and alter the adjustment on the motor-protective circuit breaker.
		Power input of the small-parts conveyor drive inadmissibly high	See point ③.
③	Power input of the small-parts conveyor drive inadmissibly high	Electromagnet (winding) defect	Please send the drive to AViTEQ Vibrationstechnik GmbH, if possible we will repair the drive
		Air gap is set too wide	Only AViTEQ Vibrationstechnik GmbH is allowed to alter the air gap, please send in the unit or ask for our service
		Working weight too low and/or natural frequency too high	Only AViTEQ Vibrationstechnik GmbH is allowed to alter the natural frequency, please send in the unit or ask for our service
④	Drive is running in collision mode (hammering noise)	Operating the small-parts conveyor drive without a controller	Only operate the small-parts conveyor drive with the appropriate controller, otherwise the ATEX-Type Examination Certification becomes invalid.
		Screws are loose	Tighten screws with the appropriate torque, because the collision of components is a possible ignition source.
		Excessive working weight and/or natural frequency too low	Only AViTEQ Vibrationstechnik GmbH is allowed to alter the natural frequency, please send in the unit or ask for our service
		Air gap is set too narrow	Only AViTEQ Vibrationstechnik GmbH is allowed to alter the air gap, please send in the unit or ask for our service
		Wrong controller chosen	Please check, if the controller and the small-parts conveyor drive match, therefore check the AViTEQ delivery information.
		Leaf spring(s) or spring mountings screw(s) broken	Please send the drive to AViTEQ Vibrationstechnik GmbH, if possible we will repair the drive
⑤	Small-parts conveyor unit output too low	Loose parts collide with the small-parts conveyor drive or unit	Remove or tighten loose parts immediately, because the collision of components is a possible ignition source.
		Wrong controller chosen	Please check, if the controller and the small-parts conveyor drive match, therefore check the AViTEQ delivery information.
		Working weight too low and/or natural frequency too high	Only AViTEQ Vibrationstechnik GmbH is allowed to alter the natural frequency, please send in the unit or ask for our service
		Working unit can not vibrate freely	Operate the small-parts conveyor unit only when it rests on rubber feet, the working unit must oscillate freely without touching any components
		Resonances at the working unit or the support construction	Eliminate resonances
		Deposits of the transported material, also ③ and ④ possible	Eliminate deposits and take further steps to avoid deposits
		Screws for tightening the working unit are too long, also ③ and ④ possible	Shorten the screws
		Check, if used, if the height of the hopper outlet is too low	Increase height of the hopper outlet, if necessary. Observe, that the maximum height of the outlet is the height of the working unit.
	Temperatures below 0°C, transported material freezes or sticks	Warm up the transported material if possible or take other steps to avoid that the material freezes or sticks.	

Table 7-1 Fault, Causes and Remedies



**NOTE!**

*Consult us, however, prior to performing error rectification measures to avoid possible damages or accidents.*



**NOTE!**

*The faults listed in the table 7-1 refer to the small-parts conveyor drive. Further faults, caused by the controller, can be found in the appropriate operating manual.*

## 8 Index

**A**  
Additional weight 22  
Air gap 19

**C**  
Cable gland 3, 29  
Checks, regular 32  
Cleaning 33  
Climate environments 12  
Collision voltage 19  
Commissioning 30  
Connection, electrical 24, 28  
Connection cable 3, 29  
Connection diagrams 26  
Construction of the small-parts conveyor drive 17  
Controller 4, 9, 24  
Copyright 7

**D**  
Declaration of conformity 36  
Description 17  
Disposal 16

**EC-Directives** 14  
Electric rectifier unit 27  
Environmental temperatures 12  
Extent of delivery 15

**F**  
Food industry 5, 12

**G**  
General conditions of delivery, domestic and abroad 10  
Grounding 29

**H**  
Hybrid operation / -mixture 6, 12

**I**  
Impact-protection lacquer 4, 6  
Intended use 2  
Installation 21, 23  
Installation personnel 13

**L**  
Line lengths 25

**M**  
Manufacturer's declaration 37  
Maintenance 32  
Maintenance work 6, 33  
Materials, allowed for making the working unit 5  
Materials, used in the units 16  
Minimum clearance 29  
Motor-protective circuit breaker 5, 26, 27

**N**  
Natural frequency 19  
Nominal current 6, 19

**O**  
Operating personnel 13  
Operative range 12  
Oscillation rate 19

**P**  
Packing materials 16  
Product liability 10  
Pull-in current 5

**Q**  
Quality system 6

**R**  
Rated current 5  
Repairs 33  
Responsibilities of the operator 13  
Returning the device 16

**S**  
Safety precautions 13  
Screw tightening torques 22, 24  
Small-parts conveyor drive 9  
Small-parts conveyor unit 9  
Sound pressure level 6, 20  
Spring mounting screws 32  
Storage 15

**T**  
Technical data 19  
Transport 15  
Troubleshooting 34  
Tuning data 18  
Tuning of the oscillation system 17

**V**  
Varistor protection unit 26, 27  
Vibrator voltage 19

**W**  
Warranty 10  
Warranty exclusions 10  
Working stroke 19  
Working unit 9, 21  
Working weight 19

---

# Declaration of Conformity

according to Appendix X B of the EC Directive 94/9/EC relating to equipment and protective systems for use in explosive atmospheres

The Manufacturer...

**AViTEQ Vibrationstechnik GmbH  
Im Gotthelf 16  
D-65795 Hattersheim-Eddersheim**

declares, that the small-parts conveyor drives of the series

<b>eKF 1-... (EEx)</b>	(110V / 50Hz) (220-240V / 50Hz)	(110V / 60Hz) (220-240V / 60Hz)
<b>eKF 6-... (EEx)</b>	(110V / 50Hz) (220-240V / 50Hz)	(110V / 60Hz) (220-240V / 60Hz)
<b>eKF12-... (EEx)</b>	(110V / 50Hz) (220-240V / 50Hz) (380-400V / 50Hz)	(110V / 60Hz) (220-240V / 60Hz) (380-400V / 60Hz)

are in conformance with the following European directive:

**94/ 9/EC**

**Directive relating to equipment and protective systems for use in explosive atmospheres**

and are classified as electrical apparatus of the equipment group II and therefore can be operated according to the following definition.



**BVS .. ATEX ..  
II 2 G EEx e IIB T4  
II 2 D IP65 T 115°C**

The conformance of the products with the European Directive is demonstrated through full observation of the following harmonized standards:

**EN 50014**

**EN 50019**

**EN 50281-1-1**

*Full technical documentation is available. The operating manual for the devices is in hand. The CE symbol has been included.*

The safety notes in the operating manual must be observed!

This declaration certifies conformance with the specified standards and directive . It does not, however, include a guarantee of characteristics.

Hattersheim-Eddersheim, 28<sup>th</sup> of October 2004

Legally binding signature:

*i.V. Holl*

---

i.V. Holl (Ex protection-representative (ExB))

# Manufacturer's Declaration

according to Appendix II B of the EC Directive 98/37/EC relating to machinery

The Manufacturer...

**AViTEQ Vibrationstechnik GmbH**  
**Im Gotthelf 16**  
**D-65795 Hattersheim-Eddersheim**

declares, that the small-parts conveyor drives of the series

<b>eKF 1-... (EEx)</b>	<b>(110V / 50Hz)</b> <b>(220-240V / 50Hz)</b>	<b>(110V / 60Hz)</b> <b>(220-240V / 60Hz)</b>
<b>eKF 6-... (EEx)</b>	<b>(110V / 50Hz)</b> <b>(220-240V / 50Hz)</b>	<b>(110V / 60Hz)</b> <b>(220-240V / 60Hz)</b>
<b>eKF12-... (EEx)</b>	<b>(110V / 50Hz)</b> <b>(220-240V / 50Hz)</b> <b>(380-400V / 50Hz)</b>	<b>(110V / 60Hz)</b> <b>(220-240V / 60Hz)</b> <b>(380-400V / 60Hz)</b>

are in conformance with the following European directive:

**98/37/EC**                      **Directive relating to machinery**

The conformance of the products with the European Directive is demonstrated through full observation of the following harmonized standards and national standards and directives:

**EN ISO 12100-1 /...-2**  
**EN 563**  
**EN 60204-1**  
**EN 60529**  
**EN 62079**

**IEC 38**  
**DIN VDE 0580**

Full technical documentation is available. The operating manual for the devices is in hand. The CE symbol has been included.

**Commissioning of the small-parts conveyor drive is prohibited until it is established that the machine with which the small-parts conveyor drive will be installed complies with the regulations of the machinery directive 98/37/EEC.**

The safety notes in the operating manual must be observed!

This declaration certifies conformance with the specified standards and directive . It does not, however, include a guarantee of characteristics.

Hattersheim-Eddersheim, 28<sup>th</sup> of October 2004

Legally binding signature:

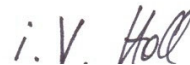

---

i.V. Holl (Ex protection-representative (ExB))

AVITEQ Vibrationstechnik GmbH  
Im Gotthelf 16  
D-65795 Hattersheim-Eddersheim

Phone: +49 / 61 45 / 5 03 - 0  
Fax: +49 / 61 45 / 5 03 - 2 00  
Fax Service-Hotline: +49 / 61 45 / 5 03 - 112  
E-Mail [service@aviteq.de](mailto:service@aviteq.de)

[www.aviteq.de](http://www.aviteq.de)

 VIB 12.90a / 1004 EN