

## Vibratory Conveyor Units with Unbalance Drive

vibratory units are easy to install and service. Installation, electrical connection, putting into operation and servicing must however, be earned out by trained personnel, the following directives being observed in the process.

### Scope of supply

Supplies of vibratory units with unbalance units comprise:

- the vibratory unit with unbalance motors
- the power unit (braking unit) with dimension sheet and connection diagram
- Circuitry recommendation for the connection of unbalance motors without braking unit
- Supporting elements (rubber blocks, suspension elements and the like)

These parts are packed separately from the vibratory unit. In the case of large spiral conveyors the top part, frame and drive pedestal with unbalance motor are likewise packed separately. All the requisite screws with accessories are included in the consignment. It is urgently recommended that a check be made upon receipt and before assembly to make sure that no parts are missing.

### Building in the vibratory unit

The vibratory unit is to be built in according to the accompanying dimension drawing so as to oscillate freely, by means of the supporting or suspension elements supplied. The bearing surfaces of the supports for compression rubber blocks or compression springs must be in the horizontal position. This applies also for inclined or rising mounting.

Vibratory units may not touch any permanently mounted structural parts. After unbraked unbalance motors are switched off it is possible for oscillation amplitudes to arise which are greater than the support-spring resonance's in normal operation. It is therefore advisable to set the distance to fixed parts at 40 to 50mm.

Disturbing oscillation amplitudes do not occur with motors connected by means of a braking unit. The vibrator/ units come to a standstill in one or two seconds.

Flexible sleeves only should be used for dustproof connections at the intake and outlet.

### Direction of motor rotation

The direction of motor rotation should be checked before putting the vibratory units into operation. For this purpose, one protective cover or the motors is removed and the vibratory unit switched on briefly. With vibrator/ conveyors and screens the motors must rotate in opposite directions, with spiral conveyors both motors must rotate in the same direction.

### Subsequent alteration of vibratory units

Structural alterations, such as the extension or shortening of a trough conveyor, affect the vibratory

characteristics and rigidity of the unit. For this reason no such alterations may be carried out. It is to a certain extent possible to incorporate wearing devices at a later date, thus reducing the delivery flow. Information and mounting instructions may be obtained from the suppliers.

### Mains connection

Check whether voltage and frequency coincide with the data on the rating plate.

The unbalance motors are connected to a three-phase a. c. system with protective conductor.

### Location and remedying of faults

The vibratory unit works at too low a conveying speed or not at all. Possible causes:

- The transport block (for spiral conveyors) has not been removed
- The direction of motor rotation does not suit the type of equipment
- The centrifugal weights are incorrectly set
- Only one motor is working
- The vibratory unit has been incorrectly installed. Check whether it can oscillate freely
- Electrical connections are faulty-check the cables for possible breaks or loose terminals. Check the fuses.

In the case of guided trough conveyors further possibilities:

- Screw connections between guide frame- and foundation have worked loose
- The foundation mass is insufficient

Blown fuses must be replaced by fuses of the same values after the cause of their failure has been remedied. In particular, the super-rapid fuses for the brake rectifier (identified by blue print or a yellow ring) may not be replaced by rapid or slow-acting fuses, as this would mean the destruction of the rectifier in the case of a short circuit.

When exchanging unbalance motors, the centrifugal weights must be adjusted as on the original motors.

Fig. 1 shows the support or suspension of **freely oscillating units, taking through conveyors and tubular conveyors** as examples. The supporting structure must be dimensioned for the weight of the vibratory unit including drive and filling of bulk material, as well as the pressure of the bulk-material column in the bin, and must also be resistant to vibration. Although the alternating forces transmitted through the flexible supporting elements are slight, they can nevertheless cause inadmissibly great resonance vibration deflections if parts of the supporting structure are not sufficiently vibration-resistant.

With vibratory units suspended on helical springs (suspension type c), the lower lug of the helical spring must be screwed fast to the holder (1). The spring axis must point in the direction of the traction rope or the suspension rod in order that the spring is not subjected to bending stress. The direction of traction must be inclined sideways by 10 to 15 deg. to prevent lateral oscillation of the unit. Catch devices must be provided in case of spring breakage.

Fig. 2 shows the fixation of a **guided through conveyor** with the foundation. The guide frame of the through conveyor or conveying line is to be screwed to the foundation in a torsion-resistant and tension-free way. The requisite foundation weights can always be seen in the accompanying dimension drawing.

With **spiral conveyors** - if not already done at works - the top part connected with the drive pedestal is placed on the frame and screwed to it by means of flexible intermediate elements, such as rubber blocks or compression springs. The frame of the spiral conveyor must be firmly anchored to the floor by means of the existing bores. The transport blocks marked with red paint must be loosened, turned through 180 deg. and screwed onto the frame with the rubber pads supplied (Fig. 3).

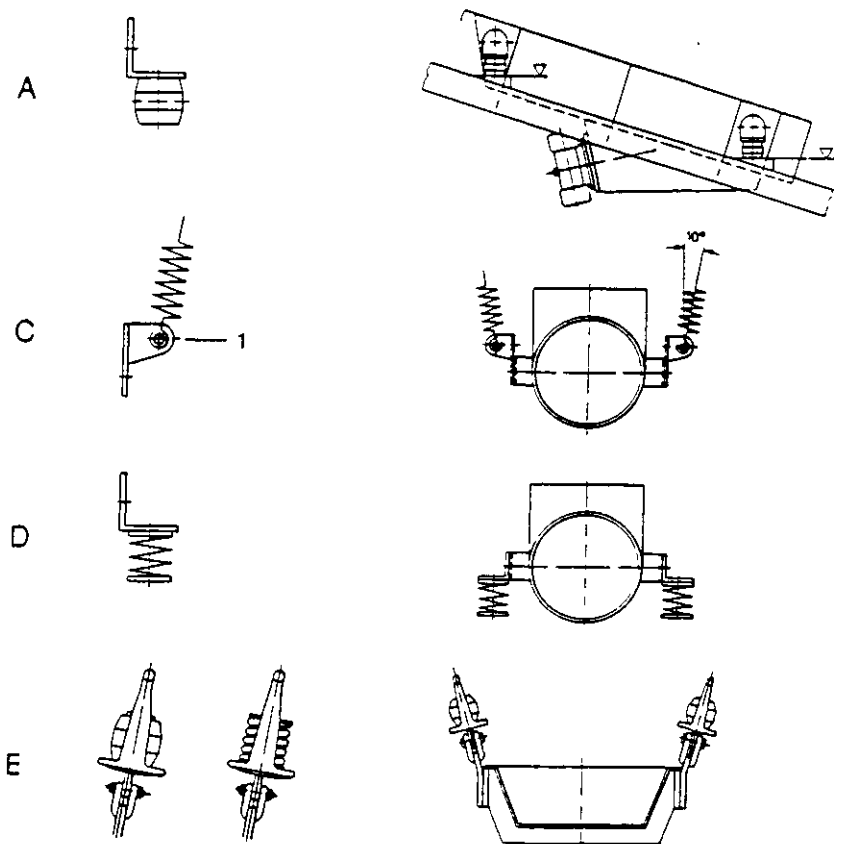

Fig. 1 Oscillation-insulated suspension of troughs and tubes

- A supported on rubber pads
- B suspended on helical springs
- C supported on compression springs
- D suspended on compression springs or pressure-stressed rubber pads
- E suspended on compression springs or pressure-stressed rubber pads
- 1 fixed screw connection

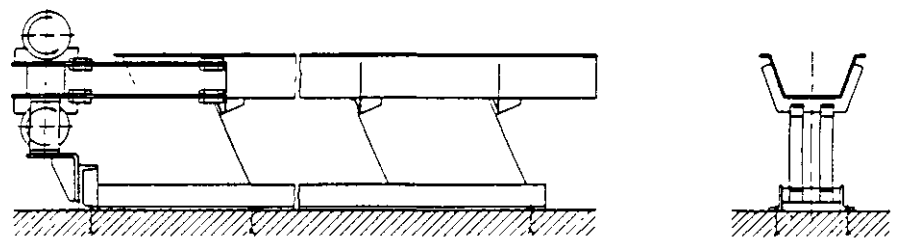

Fig. 2 Guide through conveyor with clamping to the foundation

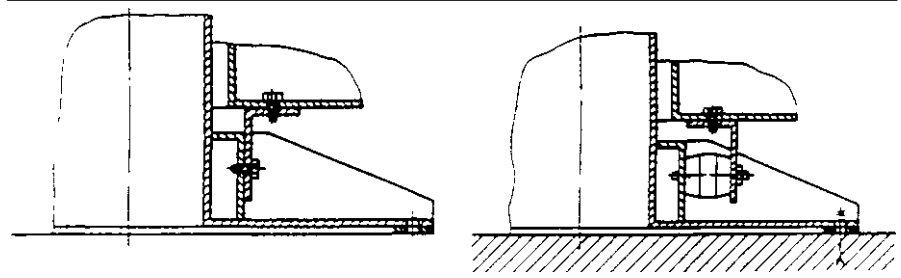

Fig. 3 Spiral conveyor with supporting frame  
left angle as transport block

right angle for fastening the rubber blocks

# Supplementary Sheet to the Operating Instructions

## For your Safety !

The following safety instructions are intended to ensure your safety and that of your colleagues.

### - During planning

AViTEQ oscillation units represent no danger as long as the following safety instructions are observed. The units are built using the latest technology and are reliable and fail-safe.

Despite oscillatory insulation being ensured via the spring elements supplied, a very small part of the oscillations might be transmitted to supports, structure, mounting parts etc.

Therefore, in addition to the static loads from the unit itself and the bulk material pressing on it, the supports and structure should also be considered in relation to dynamic loads.

The special regulations of competent employer's liability insurance associations, environmental regulations etc. are to be considered during the planning stage.

AViTEQ oscillatory units, driving gears and line connection units may only be used by trained personnel and for use according to regulations. Personnel involved with the installation, maintenance and operating of the oscillatory unit must have read and understood the operating instructions and safety regulations before handling the unit.

### - During assembly and installation work

When performing installation or assembly work use your personal protective equipment. Helmet, hard-toed boots, gloves, suitable clothing.

Before transport and assembly work is performed, ensure that the transport and hoisting equipment (ropes, chains etc.) are in good working order and remember that stoppage under suspended load is not permitted, even for a short period. Stoppage under open hoopers represents a danger to life, since residual matter sticking to the walls could come loose and fall down.

The electric supply connection may only be performed after assembly work has been completed. It is to be performed by trained personnel pursuant to VDE standards as well as the regulations of the competent employer's liability insurance associations and in accordance with the respective regulations of the Electric Supply Company. Outside of Germany, the respective national and international regulations for electrical safety are to be observed.

- **When starting**

Look out for any loose parts and remove them if necessary. On account of oscillations transmitted to supports and structure, it is possible that parts which are loose or inadequately fastened may fall down. Also think about your tools, bulk material etc.

On stimulation the vibrations could evade opposite to the direction of conveyance. Look out for squeezed and stop spots. Think about your colleagues and secure passages below the conveyance unit against falling material to be conveyed. Or even better, arrange the passages in such a way that they lead past the conveyance unit at an adequate distance.

Oscillatory driving gears may not be operated without their protective fenders, since the rotating unbalanced mass in unbalance motors and unbalance exciters, the air gap in magnetic vibrators as well as the agitated parts in slider-crank drives can create danger spots. When checking the direction of rotation of unbalance motors without hoods you must ensure that no persons are located in the danger zone. After inspection, the hoods must be re-assembled immediately.

- **In operation**

At least once a week, check the suspensions and screwed connections. Check whether the cable shows any abrasion or fractures. Any defects must be remedied immediately.

Operation without the prescribed protective facilities is not permissible. You are not allowed to perform any alterations on the unit.